

6712

ounce display – unique in POS



Ounces only point-of-sale interface scale for linking to POS systems.



shown with optional remote display post.



retail and food service weighing solutions

ounce display – unique in POS

NCI Model 6712 is designed for use in cafeterias, convenience stores, delicatessens, restaurants, candy shops or anywhere space is a premium.

SPECIFICATIONS

Capacity and Resolution

Ounces
160 x 0.1

Dimensions

Weigh Platter: 10" x 10" (254 mm x 254 mm)
Remote Display Enclosure: 5.8" W x 3.0" H x
1.4" D max (147 mm x 76 mm x 35 mm)
Adjustable Height: 2.5" – 3.0" (63 mm – 76 mm)

Power

Input: Wall mount transformer 120 VAC
(+10% -15%)/ 60 Hz (± 3 Hz)
Standard 3 wire with ground input
Output: 15 VDC @ 0.3 Amps minimum

Operating Environment

41°F to 104°F (5°C to 40°C) (Class III device)
10% to 90% RH (non-condensing)

Agency Approvals

Legal for Trade, NTEP Class III,
USA COC #95-070A5
Power Supply: UL Listed, CSA Certified



DIMENSIONS

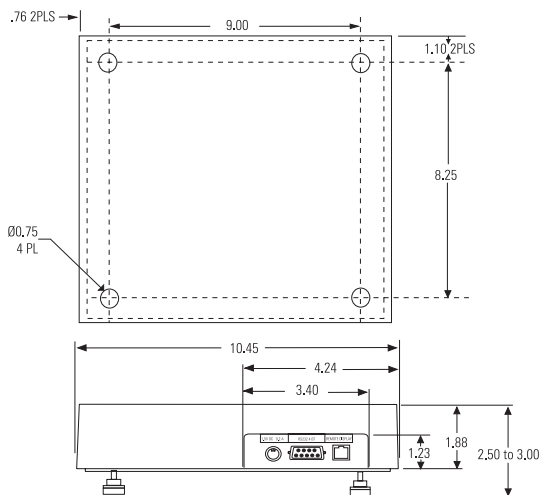

FEATURES & BENEFITS

- ◆ **Low Profile** Only 2.5" high.
- ◆ **Small Footprint** 10" x 10" platter.
- ◆ **Easy to Read** Six-digit LCD external display with large 0.5" characters, tactile keys, 7 ft. cable and Velcro™ for mounting.
- ◆ **Accurate and Reliable** Precision load cell and quality electronics ensure repeatable weight measurements and trouble-free operation.
- ◆ **Simple to Use** Reduces operator training time.
- ◆ **Easy to Install** Interfaces to most point-of-sale software programs.
- ◆ **Interfaces** RS-232 only. NCI standard protocol only.
- ◆ **Auto Zero Tracking** Zero light indicator and manual control when out of range.
- ◆ **Quick Disconnects** Make all cable connections easily.
- ◆ **Construction** Stainless steel weighing area with full skirt around perimeter of base, except where connectors are located at rear of scale.

OPTIONS

- ◆ **Display Post** 12" high post for attachment to remote display.
- ◆ **Display Brackets** Attach remote display to scale base.
- ◆ **International Power Supply** 230 VAC, 50 Hz power supply. Cable terminated with a universal connector.
- ◆ **Cables** Interface cables available for PCs and specific ECRs.



retail and food service weighing solutions

Avery Berkel North America
3133 E 150 N
LaPorte, IN 46350

PH Toll-Free: 800-237-1886
PH: 219-325-9587

FAX Toll-Free: 800-237-2063
FAX: 219-325-9594

sales@AveryBerkelUSA.com
www.AveryBerkelUSA.com



As we continually strive to improve our products, specifications are necessarily subject to change without notice. Product complies with F.C.C..

