

6720

the benchmark in POS weighing



shown with internal display and optional remote post display



shown with remote display

Point-of-sale interface scale for linking to electronic cash registers or POS terminals.



retail and food service weighing solutions

the benchmark in POS weighing

NCI Model 6720 is designed for use in grocery and health food stores, cafeterias, convenience stores, candy shops, hardware stores, pet stores or other retail locations.

SPECIFICATIONS

Capacity/Resolution

Pounds	Kilograms
15 x 0.005	7 x 0.002
30 x 0.01	15 x 0.005
60 x 0.02	30 x 0.01

Dimensions

Weigh Platter: 12" x 14" (305 mm x 356 mm)
Adjustable Height: 4.1" - 4.6" (104 mm - 117 mm)

Power

120 VAC (+10% -15%) / 60 Hz (±3 Hz)
Standard 3 wire with ground
Output: 15 VDC @ 0.3 Amps minimum

Operating Environment

41°F to 104°F (5°C to 40°C) (Class III device) 10% to 90% RH (non-condensing)

Agency Approvals

Legal for Trade, NTEP Class III,
USA COC #95-070A5
Canada: MOI approval #AM-5076 Rev. 2
Power Supply: UL Listed, CSA, CE Certified



DIMENSIONS

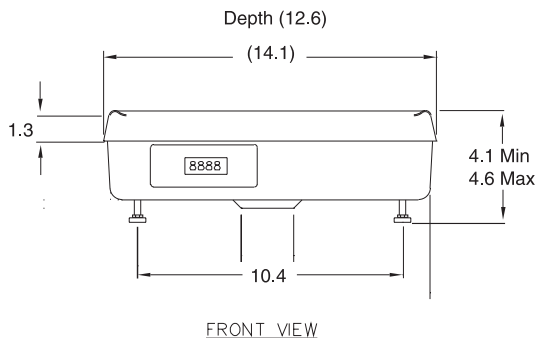

FEATURES & BENEFITS

- ◆ **Spacious Footprint** 12" x 14" stainless steel dished platter.
- ◆ **Easy to Read** Six-digit LCD display with large 0.5" characters.
- ◆ **Accurate and Reliable** Precision load cell and quality electronics ensure repeatable weight measurements and trouble-free operation.
- ◆ **Simple to Use** Reduces operator training time.
- ◆ **Easy to Install** Interfaces to most electronic cash registers and point-of-sale software programs.
- ◆ **Interfaces** RS-232, 4-bit parallel, 40-bit serial, and OPOS.
- ◆ **Interface Protocols** ECR (NCI Standard), Mettler Toledo, CAS.
- ◆ **Quick Disconnects** Make all cable connections easily.
- ◆ **Construction** Die-cast base and load bridge reduces overall scale deflection and provides overload protection to safeguard load cell and extend life of scale.

OPTIONS

- ◆ **Display Post** 12" high post for attachment to remote display.
- ◆ **Remote Display** Six-digit LCD housed in an extruded metal enclosure with tactile keys and a 7 ft. cable.
- ◆ **International Power Supply** 230 VAC, 50 Hz power supply. Cable terminated with a universal connector.
- ◆ **PC Interface Cable** RS-232 serial pass-through cable with DB-9 pin female connector to PC.



retail and food service weighing solutions

Avery Berkel North America
3133 E 150 N
LaPorte, IN 46350

PH Toll-Free: 800-237-1886
PH: 219-325-9587

FAX Toll-Free: 800-237-2063
FAX: 219-325-9594

sales@AveryBerkelUSA.com
www.AveryBerkelUSA.com



As we continually strive to improve our products, specifications are necessarily subject to change without notice. Product complies with F.C.C..

